



SERVICE PARTS MANUAL
CIM SERIES
CIM0835, CIM0836, CIM1135 CIM1136 and CIM1137



This parts list contains the service parts available for the following CIM Series.

CIM0836 208-230/60/1
CIM0836G 208-230/60/1

CIM0835 220-240/50/1

CIM1136 208-230/60/1
CIM1137 208-230/60/3

CIM1135 220-240/50/1

Model Number Example

CIM0836HA

CIM = **C**uber **I**ce **M**achine

08 = 800 lb, in 24 hours capacity

3 = 30 inch wide cabinet

0 = 115 Volt, **5** = 220-240/50/1 **6** = 208-230/60/1 Volt

H = Half Cube Size, **F** = Full Cube Size **G**=Grande Cube Size

A = Air Cooled Condenser, **W** = Water Cooled Condenser **R**=Remote Condenser

Check the model number on the data plate and refer to the correct listing for the specific component.

Check carefully that the correct part is identified and ordered.

Table of Contents	Page 1
Cabinet	Page 2-3
Water System	Page 4-5
Air Cooled Condenser	Page 6-7
Water Cooled Condenser	Page 8-9
Remote Condenser	Page 10-11
Electrical	Page 12-15

Ice-O-Matic
11100 East 45th Ave.
Denver Co. 80239
800-423-3367

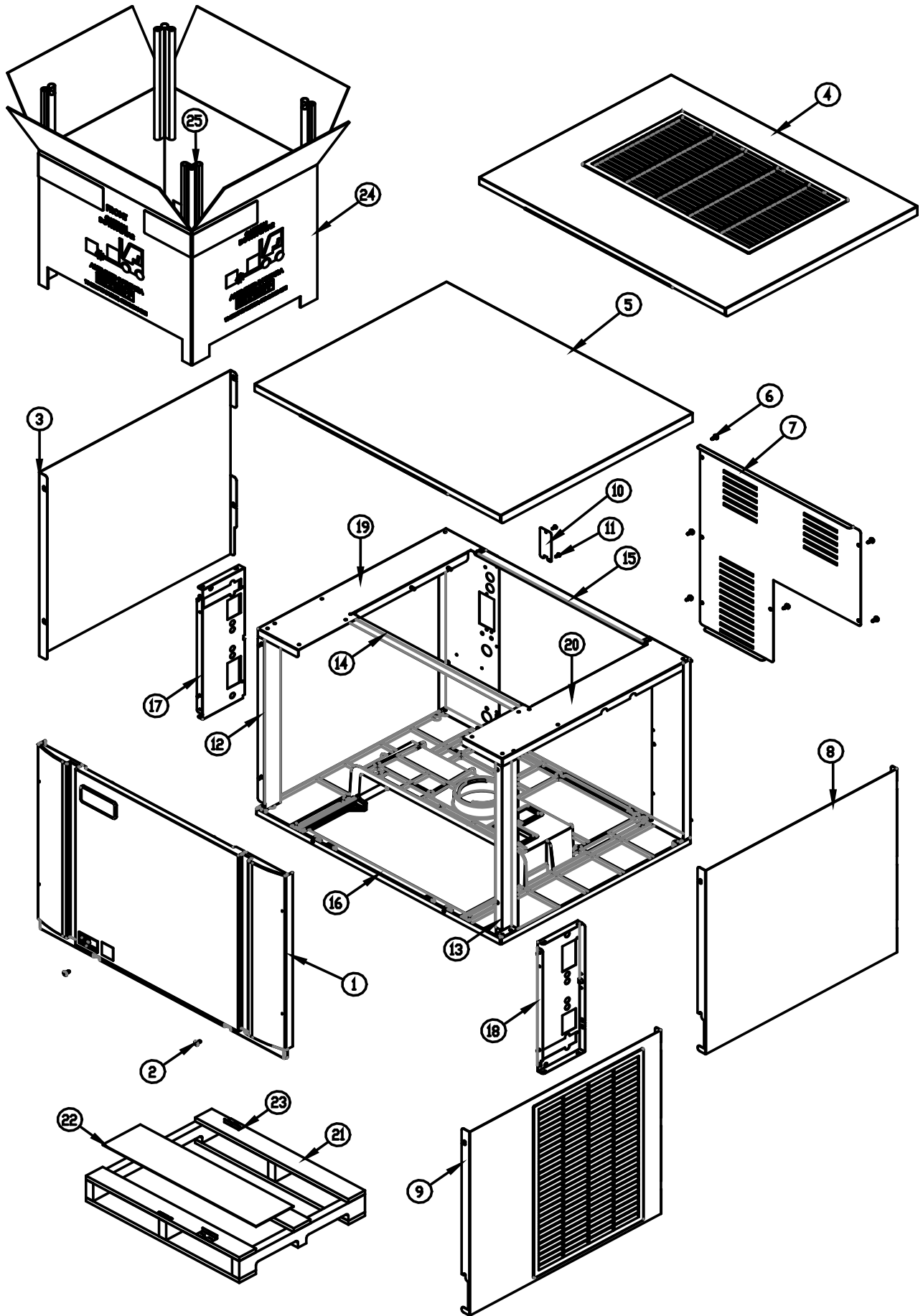

Item No.	Model Number			Description
	CIM0836		CIM1136	
1	2031544-01S		2031544-01S	2031544-01S Front Panel
2	9031237-01		9031237-01	9031237-01 Front Panel Screws
3	3022007-05		3022007-05	3022007-05 Left Side Side Panel
4	2101496-02S		2101496-02S	2101496-02S Top Panel-Air Cooled
5	3022012-03		3022012-03	3022012-03 Top Panel-Remote and Water Cooled
6	9031046-01P		9031046-01P	9031046-01P Rear Cover Screws
7	3013634-01		3013634-01	3013634-01 Rear Cover
8	3022007-06		3022007-06	3022007-06 Right Side Panel-Remote and Water Cooled
9	3022007-04		3022007-04	3022007-04 Right Side Panel-Air Cooled
10	3013674-01		3013674-01	3013674-01 Junction Box Cover
11	9031046-01P		9031046-01P	9031046-01P Junction Box Screw
12	2021801-01		2021801-01	2021801-01 Left Front Corner Post
13	2021801-02		2021801-02	2021801-02 Right Front Corner post
14	3013637-02		3013637-02	3013637-02 Brace 30 Inch
15	3013636-01		3013636-01	3013636-01 Rear Brace
16	9051725-02		9051725-02	9051725-02 Base
17	2021800-01		2021800-01	2021800-01 Front Left Brace
18	2021800-02		2021800-02	2021800-02 Front Right Brace
19	2021798-01		2021798-01	2021798-01 Right Side Framework 30"Assembly
20	2021799-01		2021799-01	2021799-01 Left Side Framework 30"Assembly
21	9011369-02		9011369-02	9011369-02 Elevation Skid 30 Inch
22	9011378-01		9011378-01	9011378-01 Carton Liner 30 Inch
23	9051765-01		9051765-01	9051765-01 Shipping Bracket 2 Req. (Field Installed)
24	9011374-05		9011374-05	9011374-05 Carton, Elevation 30 Inch
25	9011320-06		9011320-06	9011320-06 Corner Post (Each), Elevation, (4 Required)
	9031026-04P		9031026-04P	9031026-04P Pop Rivets Not Shown (Package of 10)

	CIM0835		CIM1135		Description
1	2031544-01S		2031544-01S		Front Panel
2	9031237-01		9031237-01		Front Panel Screws
3	3022007-05		3022007-05		Left Side Side Panel
4	2101496-02S		2101496-02S		Top Panel-Air Cooled
5	3022012-03		3022012-03		Top Panel-Remote and Water Cooled
6	9031046-01P		9031046-01P		Rear Cover Screws
7	3013634-01		3013634-01		Rear Cover
8	3022007-06		3022007-06		Right Side Panel-Remote and Water Cooled
9	3022007-04		3022007-04		Right Side Panel-Air Cooled
10	3013674-01		3013674-01		Junction Box Cover
11	9031046-01P		9031046-01P		Junction Box Screw
12	2021801-01		2021801-01		Left Front Corner Post
13	2021801-02		2021801-02		Right Front Corner Post
14	3013637-02		3013637-02		Brace 30 Inch
15	3013636-01		3013636-01		Rear Brace
16	9051725-02		9051725-02		Base
17	2021800-01		2021800-01		Front Left Brace
18	2021800-02		2021800-02		Front Right Brace
19	2021798-01		2021798-01		Right Side Framework 30"Assembly
20	2021799-01		2021799-01		Left Side Framework 30"Assembly
21	9011369-02		9011369-02		Elevation Skid 30 Inch
22	9011378-01		9011378-01		Carton Liner 30 Inch
23	9051765-01		9051765-01		Shipping Bracket 2 Req. (Field Installed)
24	9011374-05		9011374-05		Carton, Elevation 30 Inch
25	9011320-06		9011320-06		Corner Post (Each), Elevation, (4 Required)
	9031026-04P		9031026-04P		Pop Rivets Not Shown (Package of 10)

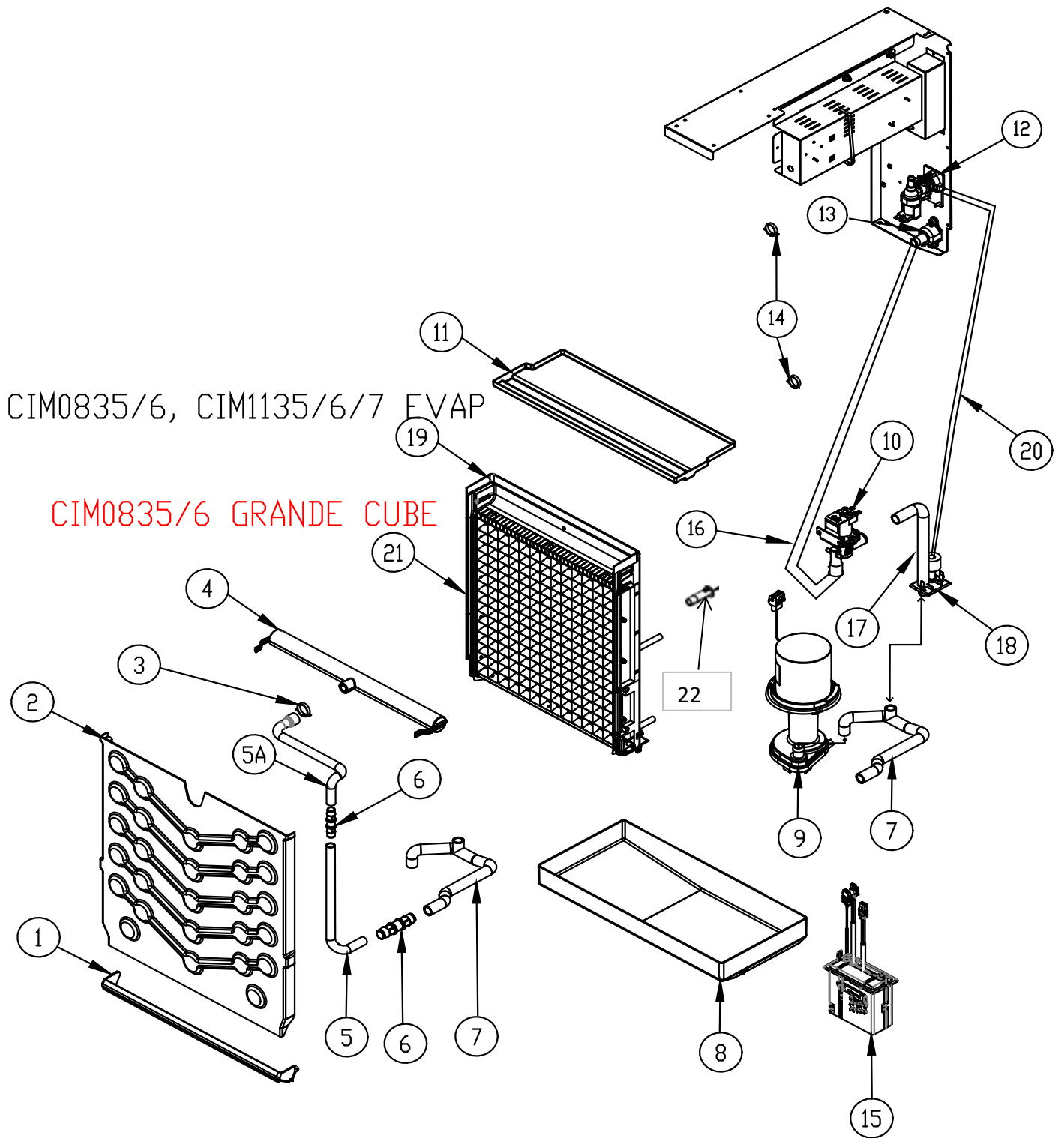

The Model Number of the machine has a designator for the Cube Size

Example: **CIM0836FA** **F = Full Cube**

CIM0836HA **H = Half Cube**

CIM0836GA **G = GRANDE Cube**

Item No.	Model Number				Description	
	CIM0836	CIM0836G		CIM1136		CIM1137
1	9051823-01	9051823-01		9051823-01	9051823-01	Lower Curtain Assembly
2	9051760-01	9051760-01		9051760-01	9051760-01	Evaporator Cover ("Splash Guard")
3	9021010-05	9021010-05		9021010-05	9021010-05	Hose Clamp, Plastic
4	9051766-01	9051766-01		9051766-01	9051766-01	Water Distribution Tube Assembly
5	9051749-05	9051749-05		9051749-05	9051749-05	Water Tube, Side
5A	9051780-01	9051780-01		9051780-01	9051780-01	Water Tube Upper
6	9091177-01	9091177-01		9091177-01	9091177-01	Coupler, Straight, 5/8 I.D. Tubing
7	9051748-01	9051748-01		9051748-01	9051748-01	Water Tube, Sump
8	9051737-01	9051737-01		9051737-01	9051737-01	Sump/Water Trough
9	2062336-03S	2062336-03S		2062336-03S	2062336-03S	Water Pump
10	9041105-05	9041105-05		9041105-05	9041105-05	Purge Valve
11	9051738-01	9051738-01		9051738-01	9051738-01	Top Cover
12	9041108-02	9041108-02		9041108-02	9041108-02	Water Inlet Valve
13	9091140-01	9091140-01		9091140-01	9091140-01	Drain Fitting
14	9021010-04	9021010-04		9021010-04	9021010-04	Hose Clamp, Plastic
15	1051224-01	1051224-01		1051224-01	1051224-01	Float Switch Assembly (Includes Instructions)
16	9051781-30	9051781-30		9051781-30	9051781-30	Purge Valve Tubing to Drain
17	9051541-01	9051541-01		9051541-01	9051541-01	Purge Valve Tube to Inlet Outlet Bracket
18	9051739-01	9051739-01		9051739-01	9051739-01	Inlet Outlet Bracket
19	1051380-01			1051380-01	1051380-01	Evaporator-FULL Cube tp (1051223-05 NLA)
19	1051380-02			1051380-02	1051380-02	Evaporator-HALF Cube tp (1051223-06 NLA)
20	9051270-36	9051270-36		9051270-36	9051270-36	Water Inlet Valve to Inlet Outlet Bracket Tube
21		1051380-03				Evaporator-Grande Cube tp (1051223-07NLA)
22	9051744-01	9051744-01		9051744-01	9051744-01	Harvest Assist Guide
	208-230/60/1	208-230/60/1		208-230/60/1	208-230/60/3	← Machine Voltage

The Model Number of the machine has a designator for the Cube Size

Example: CIM0838FA F = Full Cube Cube Size = 7/8 x 7/8 x 7/8
 CIM0836G G = Grande Cube Cube Size = 1 1/4 x 1 1/8 x 7/8
 CIM0836HA H = Half Cube Cube Size = 3/8 x 7/8 x 7/8

Item No.	Model Number 220-240/50/1				Description
	CIM0835	CIM0835G		CIM1135	
1	9051823-01	9051823-01		9051823-01	Lower Curtain Assembly
2	9051760-01	9051760-01		9051760-01	Evaporator Cover ("Splash Guard")
3	9021010-05	9021010-05		9021010-05	Hose Clamp, Plastic
4	9051766-01	9051766-01		9051766-01	Water Distribution Tube Assembly
5	9051749-05	9051749-05		9051749-05	Water Tube, Side
5A	9051749-03	9051749-03		9051749-03	Water Tube Upper
6	9091177-01	9091177-01		9091177-01	Coupler, Straight, 5/8 I.D. Tubing
7	9051748-01	9051748-01		9051748-01	Water Tube, Sump
8	9051737-01	9051737-01		9051737-01	Sump/Water Trough
9	2062336-03S	2062336-03S		2062336-03S	Water Pump
10	9041105-05	9041105-05		9041105-05	Purge Valve
11	9051738-01	9051738-01		9051738-01	Top Cover
12	9041108-02	9041108-02		9041108-02	Water Inlet Valve
13	9091140-01	9091140-01		9091140-01	Drain Fitting
14	9021010-04	9021010-04		9021010-04	Hose Clamp, Plastic
15	1051224-01	1051224-01		1051224-01	Float Switch Assembly (Includes Instructions)
16	9051781-30	9051781-30		9051781-30	Purge Valve Tubing to Drain
17	9051541-01	9051541-01		9051541-01	Purge Valve Tube to Inlet Outlet Bracket
18	9051739-01	9051739-01		9051739-01	Inlet Outlet Bracket
19	1051380-01			1051380-01	Evaporator-FULL Cube tp (1051223-05 NLA)
19	1051380-02			1051380-02	Evaporator-HALF Cube tp (1051223-06 NLA)
20	9051270-36	9051270-36		9051270-36	Water Inlet Valve to Inlet Outlet Bracket Tube
21		1051380-03			Evaporator-Grande Cube tp (1051223-07 NLA)
22	9051744-01	9051744-01		9051744-01	Harvest Assist Guide

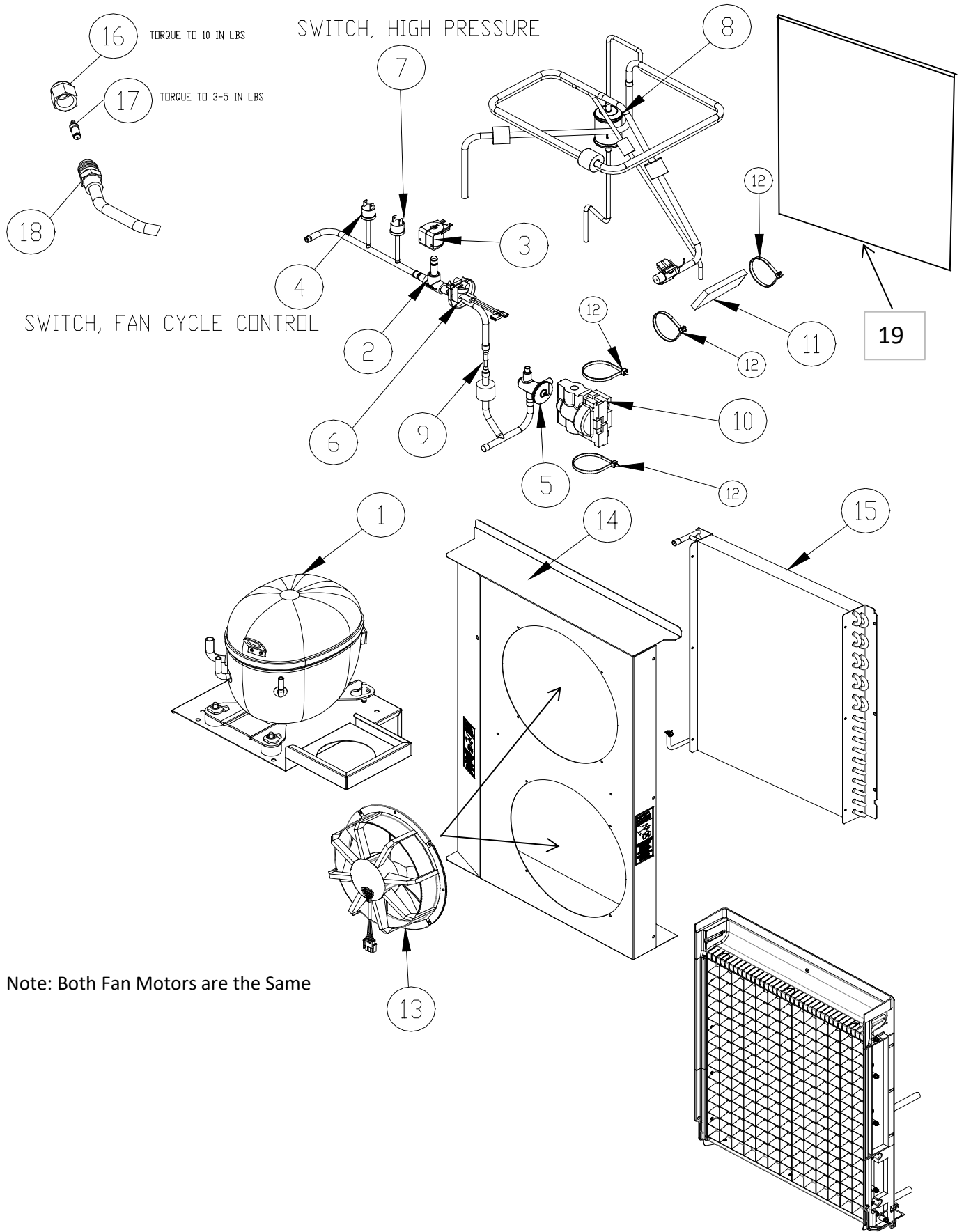

Note: Both Fan Motors are the Same

REFERENCE PAGE 4 AND 5 FOR EVAPORATOR

CIM Service Parts

Air Cooled

Note: G=Grande Cube in the Machine Model Number 60 hz.

Item No.	Model Number				Description	
	CIM0836A	CIM0836GA		CIM1136A		CIM1137A
1	1051239-11	NA		1051240-01	1051240-03	Compressor Kit (Bristol to Copeland)
1	9181139-11	9181240-11		9181240-11	9181140-13	Compressor (Copeland) (Rev 1 & after)
2	9151192-01	9151198-01		9151192-02	9151192-02	Hot Gas Valve Body
3	9151193-02	9151193-02		9151193-02	9151193-02	Hot Gas Valve Coil (240 V)
4	9041106-01	9041106-01		9041106-01	9041106-01	Switch, Fan Cycle
5	9151152-101	9151152-101		9151152-101	9151152-101	TXV
6	9041098-02	9041098-02		9041098-02	9041098-02	High Temp Switch
7	9041111-01	9041111-01		9041111-01	9041111-01	Switch, High Pressure
8	9151163-03	9151163-03		9151163-03	9151163-03	Drier (Included in Compressor Kit)
9	Not Used	Not Used		Not Used	Not Used	Restrictor
10	9131544-01	9131544-01		9131544-01	9131544-01	Insulation, TXV
11	9131143-07	9131143-07		9131143-07	9131143-07	Insulation, Bulb
12	9021021-01	9021021-01		9021021-01	9021021-01	Cable Tie-For TXV and Bulb Insulation
13	9161135-02	9161135-02		9161135-02	9161135-02	Fan Motor Assembly
13	9161143-02	9161143-02		9161143-02	9161143-02	Fan Motor Assembly (Revision 1 & after)
14	3013697-02	3013697-02		3013697-02	3013697-02	Fan Shroud
15	9141153-01	9141153-01		9141153-01	9141153-01	Condenser
16	9091086-03	9091086-03		9091086-03	9091086-03	Service Valve Cap
17	9091086-02	9091086-02		9091086-02	9091086-02	Service Valve Core
18	9091086-01	9091086-01		9091086-01	9091086-01	Service Valve Stem
19	AFK-2	AFK-2		AFK-2	AFK-2	Air Filter
	208-230/60/1	208-230/60/1		208-230/60/1	208-230/60/3	← Machine Voltage

Note: G=Grande Cube in the Machine Model Number 50 hz.

Item No.	Model Number				Description	
	CIM0835A	CIM0835GA		CIM1135A		
1BC	1051240-02	NA		1051241-02		Compressor Kit (Bristol to Copeland)
1CR1	9181140-12	9181141-12		9181141-12		Compressor (Copeland) (Rev 1 & after)
2	9151192-01	9151198-01		9151192-02		Hot Gas Valve Body
3	9151193-02	9151193-02		9151193-02		Hot Gas Valve Coil (240 V)
4	9041106-01	9041106-01		9041106-01		Switch, Fan Cycle
5	9151152-101	9151152-101		9151152-101		TXV
6	9041098-02	9041098-02		9041098-02		High Temp Switch
7	9041111-01	9041111-01		9041111-01		Switch, High Pressure
8	9151163-03	9151163-03		9151163-03		Drier (Included in Compressor Kit)
9	Not Used	Not Used		Not Used		Restrictor
10	9131544-01	9131544-01		9131544-01		Insulation, TXV
11	9131143-07	9131143-07		9131143-07		Insulation, Bulb
12	9021021-01	9021021-01		9021021-01		Cable Tie-For TXV and Bulb Insulation
13	9161135-02	9161135-02		9161135-02		(Both Motors the Same)
13	9161143-02	9161143-02		9161143-02	9161143-02	Fan Motor Assembly (Revision 1)
14	3013697-02	3013697-02		3013697-02		Fan Shroud
15	9141153-01	9141153-01		9141153-01		Condenser
16	9091086-03	9091086-03		9091086-03		Service Valve Cap
17	9091086-02	9091086-02		9091086-02		Service Valve Core
18	9091086-01	9091086-01		9091086-01		Service Valve Stem
19	AFK-2	AFK-2		AFK-2		Air Filter
	220-240/50/1	220-240/50/1		220-240/50/1		← Machine Voltage

Reference Page 14 for Compressor Starting Components

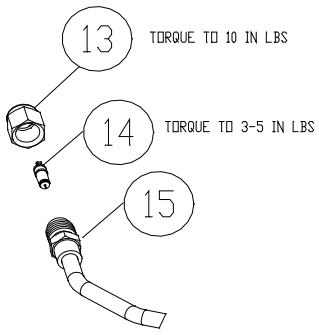

SWITCH, HIGH PRESSURE

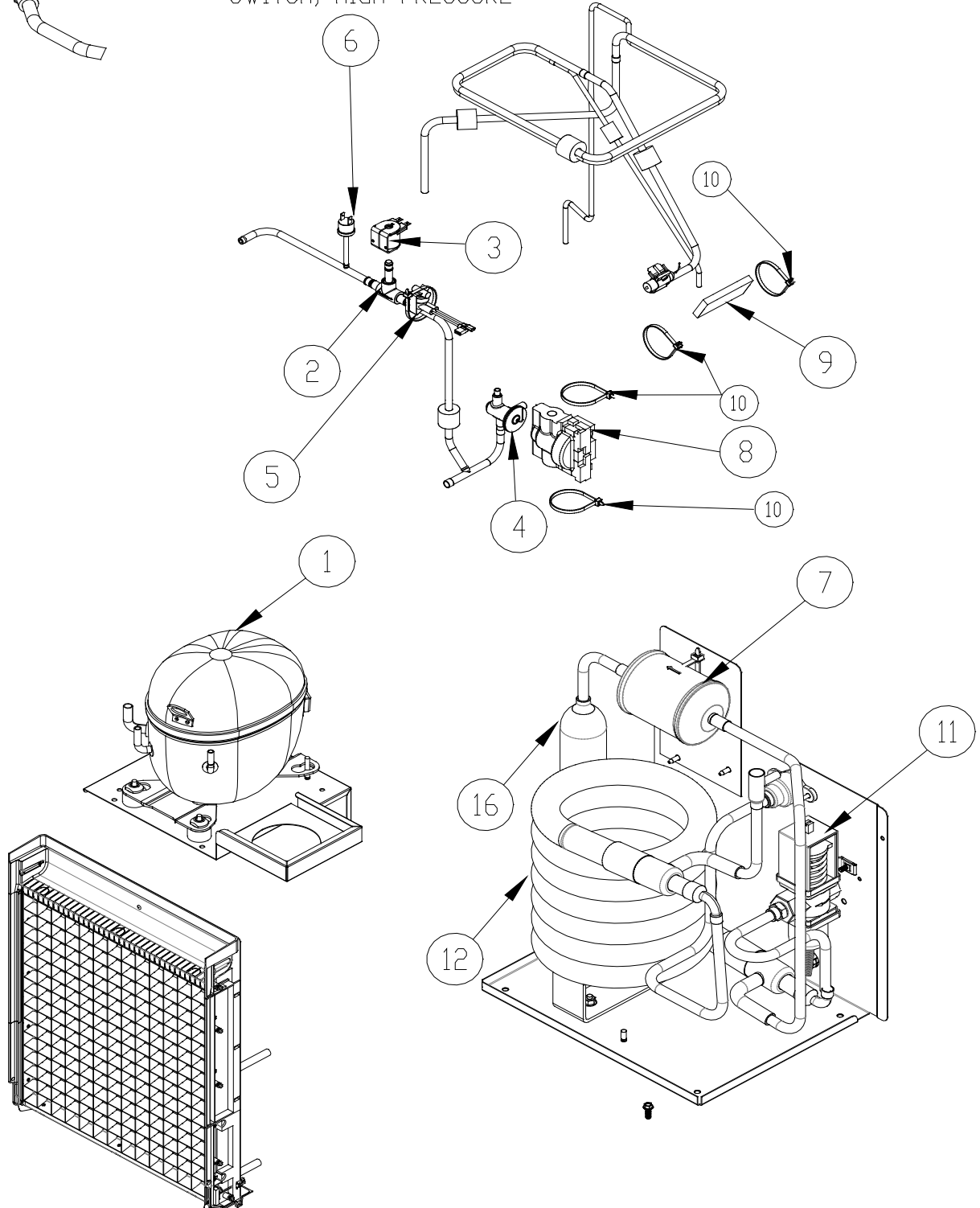

REFERENCE PAGE 4 AND 5 FOR EVAPORATOR

Item No.	Model Number			Description		
1BC	CIM0836W		CIM1136W		CIM1137W	Description
	1051239-01		1051240-01		1051240-03	Compressor
1CR1	9181139-11		9181240-11		9181140-13	Compressor (Copeland) (Rev 1 & after)
2	9151192-01		9151198-01		9151198-01	Hot Gas Valve Body
3	9151193-02		9151193-02		9151193-02	Hot Gas Valve Coil
4	9151152-101		9151152-101		9151152-101	TXV
5	9041098-02		9041098-02		9041098-02	High Temp Switch
6	9041111-01		9041111-01		9041111-01	Switch, High Pressure
7	9151163-02		9151163-02		9151163-02	Drier (Included in Compressor Kit)
8	9131544-01		9131544-01		9131544-01	Insulation, TXV
9	9131143-07		9131143-07		9131143-07	Insulation, Bulb
10	9021021-01		9021021-01		9021021-01	Cable Tie-For TXV and Bulb Insulation
11	9041059-01		9041059-01		9041059-01	Water Regulator
12	9141157-01		9141157-01		9141157-01	Condenser
13	9091086-03		9091086-03		9091086-03	Service Valve Cap
14	9091086-02		9091086-02		9091086-02	Service Valve Core
15	9091086-01		9091086-01		9091086-01	Service Valve Stem
16	9151155-01		9151155-01		9151155-01	Accumulator
	208-230/60/1		208-230/60/1		208-230/60/3	← Machine Voltage

Item No.	Model Number			Description	
1BC	CIM0835W		CIM1135W		Description
	1051240-02		1051241-02		Compressor
1CR1	9181140-12		9181141-12		Compressor (Copeland) (Rev 1)
2	9151192-01		9151198-01		Hot Gas Valve Body
3	9151193-02		9151193-02		Hot Gas Valve Coil
4	9151152-101		9151152-101		TXV
5	9041098-02		9041098-02		High Temp Switch
6	9041111-01		9041111-01		Switch, High Pressure
7	9151163-02		9151163-02		Drier (Included in Compressor Kit)
8	9131544-01		9131544-01		Insulation, TXV
9	9131143-07		9131143-07		Insulation, Bulb
10	9021021-01		9021021-01		Cable Tie-For TXV and Bulb Insulation
11	9041059-01		9041059-01		Water Regulator
12	9141157-01		9141157-01		Condenser
13	9091086-03		9091086-03		Service Valve Cap
14	9091086-02		9091086-02		Service Valve Core
15	9091086-01		9091086-01		Service Valve Stem
16	9151155-01		9151155-01		Accumulator
	220-240/50/1		220-240/50/1		← Machine Voltage

Reference Page 14 for Compressor Starting Components

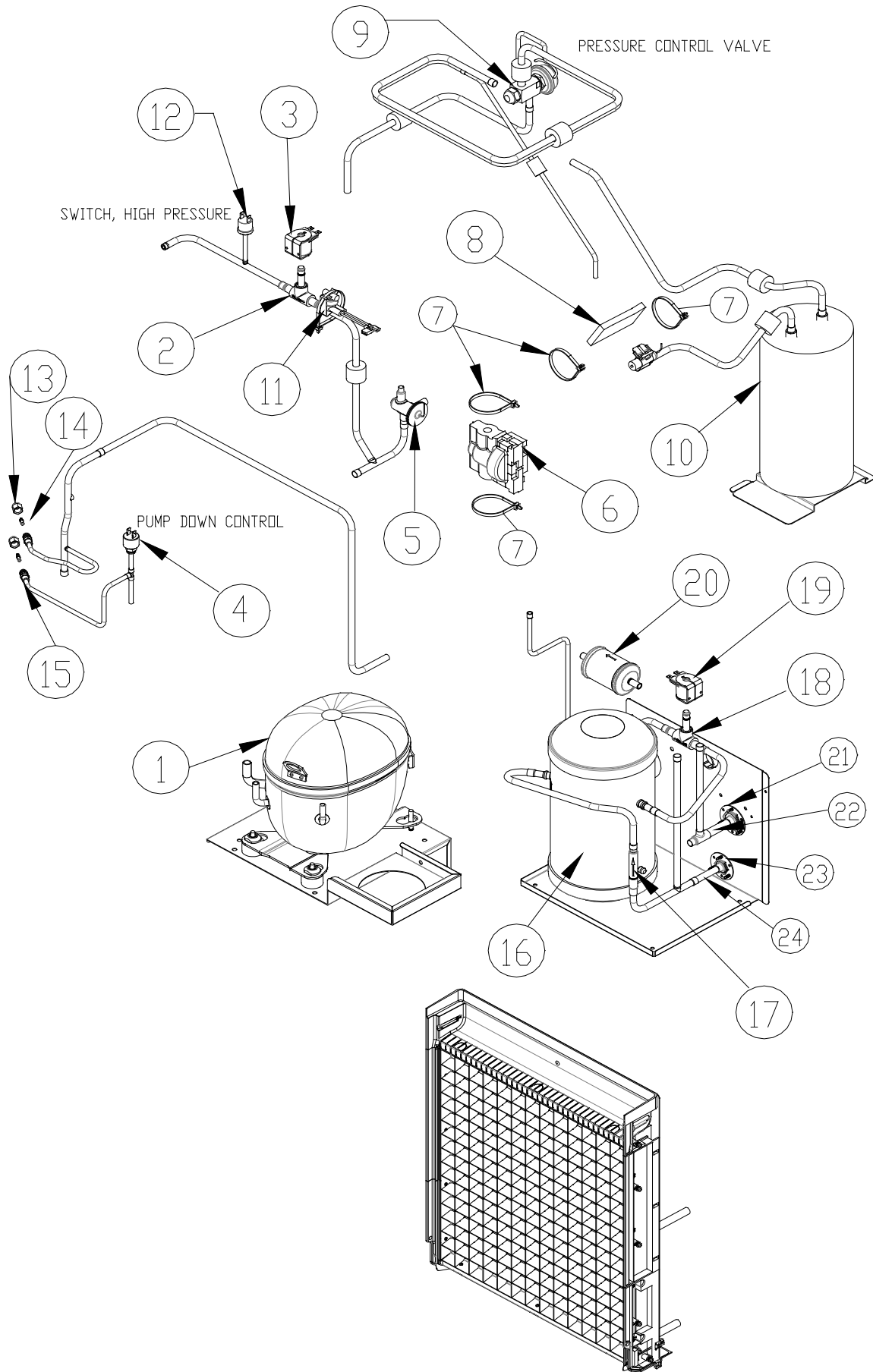

REFERENCE PAGE 4 AND 5 FOR EVAPORATOR

Item No.	Model Number					Description
	CIM0836R	CIM0835R	CIM1136R	CIM1135R	CIM1137R	
1	1051239-01	1051240-02	1051240-01	1051241-02	1051240-13	Compressor Kit (Bristol to Copeland)
1	9181139-11	9181140-12	9181240-11	9181141-12	9181140-13	Compressor (Copeland) (Rev 1)
2	9151192-01	9151192-01	9151192-02	9151192-02	9151192-02	Hot Gas Valve Body
3	9151193-02	9151193-02	9151193-02	9151193-02	9151193-02	Hot Gas Valve Coil
4	9041092-02	9041092-02	9041092-02	9041092-02	9041092-02	Pump Down Control
5	9151152-101	9151152-101	9151152-101	9151152-101	9151152-101	TXV
6	9131544-01	9131544-01	9131544-01	9131544-01	9131544-01	Insulation, TXV
7	9021025-01	9021025-01	9021025-01	9021025-01	9021025-01	Cable Tie-For TXV and Bulb Insulation
8	9131143-07	9131143-07	9131143-07	9131143-07	9131143-07	Insulation, TXV Bulb
9	NA	NA	NA	NA	NA	Pressure Control Valve
10	NA	NA	NA	NA	NA	Accumulator
11	9041098-02	9041098-02	9041098-02	9041098-02	9041098-02	High Temp Switch
12	9041111-01	9041111-01	9041111-01	9041111-01	9041111-01	Switch, High Pressure
13	9091086-03	9091086-03	9091086-03	9091086-03	9091086-03	Service Valve Cap
14	9091086-02	9091086-02	9091086-02	9091086-02	9091086-02	Service Valve Core
15	9091086-01	9091086-01	9091086-01	9091086-01	9091086-01	Service Valve Stem
16	9151060-01	9151060-01	9151060-01	9151060-01	9151060-01	Receiver
17	9151139-01	9151139-01	9151139-01	9151139-01	9151139-01	Check Valve
18	9151192-02	9151192-02	9151192-02	9151192-02	9151192-02	Liquid Line Solenoid
19	9151193-02	9151193-02	9151193-02	9151193-02	9151193-02	Liquid Line Coil
20	9151163-03	9151163-03	9151163-03	9151163-03	9151163-03	Drier (Included in Compressor Kit)
21	9091001-09	9091001-09	9091001-09	9091001-09	9091001-09	1/2 Inch Coupling Flange (Large)
22	9091001-12	9091001-12	9091001-12	9091001-12	9091001-12	1/2 Inch Coupling (Large)
23	9091001-03	9091001-03	9091001-03	9091001-03	9091001-03	3/8 Inch Coupling Flange (Small)
24	9091001-11	9091001-11	9091001-11	9091001-11	9091001-11	3/8 Inch Coupling (Small)
	208-230/60/1	220-240/50/1	208-230/60/1	220-240/50/1	208-230/60/3	← Machine Voltage

Reference Page 14 for Compressor Starting Components

Item No.	Model Number				Description
	CIM0836	CIM0836GA	CIM1136W	CIM1137W	
1					
2					
3					
4					
5					
6	9041098-02	9041098-02	9041098-02	9041098-02	Switch, High Temp
7	9101002-06	9101002-06	9101002-06	9101002-06	Contactora
8	9021096-01	9021096-01	9021096-01	9021096-01	Cable Tie, Metal
9	9041108-02	9041108-02	9041108-02	9041108-02	Valve, Water Inlet
10	2062336-03S	2062336-03S	2062336-03S	2062336-03S	Water Pump
11	9041105-05	9041105-05	9041105-05	9041105-05	Purge Valve
12	9091140-01	9091140-01	9091140-01	9091140-01	Purge Drain
13	1051224-01	1051224-01	1051224-01	1051224-01	Float Switch Assembly (Includes Instructions)
	9041112-01	9041112-01	9041112-01	9041112-01	Thermister
14	9101368-02	9101368-02	9101368-02	9101368-02	Board Dual Voltage
15	9051698-01P	9051698-01P	9051698-01P	9051698-01P	Plastic Standoff, Control Board (Pkg of 10)
16	9161134-02	9161134-02	9161134-02	9161134-02	Harvest Assist
17	9101394-01	9101394-01	9101394-01	9101394-01	Membrane Switch
18	9101379-01	9101379-01	9101379-01	9101379-01	Switch, Magnetic Reed (Bin Control On Evap)
	208-230/60/1	208-230/60/1	208-230/60/1	208-230/60/1	← Machine Voltage

Item No.	Model Number 220-240/50/1				← Machine Voltage
1					
2					
3					
4					
5					
6	9041098-02		9041098-02		Switch, High Temp
7	9101002-06		9101002-06		Contactora
8	9021096-01		9021096-01		Cable Tie, Metal
9	9041108-02		9041108-02		Valve, Water Inlet
10	2062336-03S		2062336-03S		Water Pump
11	9041105-05		9041105-05		Purge Valve
12	9091140-01		9091140-01		Purge Drain
13	1051224-01		1051224-01		Float Switch Assembly (Includes Instructions)
	9041112-01		9041112-01		Thermister
14	9101368-02		9101368-02		Board Dual Voltage
15	9051698-01P		9051698-01P		Plastic Standoff, Control Board (Pkg of 10)
16	9161134-02		9161134-02		Harvest Assist
17	9101394-01		9101394-01		Membrane Switch
18	9101379-01		9101379-01		Switch, Magnetic Reed (Bin Control On Evap)

When a CIM Series Cuber is mounted on a dispenser, the KCUBEDISP install kit is required.

Replacement Thermostatic Bin Control Part Number 9041097-01

CIM0836A	CIM0836GA		CIM1136A	CIM1137A	Starting Components (Included in Comp Kit)
9181177-11	9181180-11		9181180-11	9181181-11	Compressor Kit RED=NLA
9181003-44	9181003-44		9181003-44	N/A	Start Capacitor
9181009-16	9181009-16		9181009-16	N/A	Run Capacitor
9181010-37	9181010-33		9181010-33	N/A	Compressor Relay
Internal	Internal		Internal	Internal	Overload
CIM0835A	CIM0835GA		CIM1135A		Starting Components (Included in Comp Kit)
9181176-11	9181182-11		9181182-11		Compressor Kit RED=NLA
9181003-53	9181003-56		9181003-56		Start Capacitor
9181009-16	9181009-27		9181009-27		Run Capacitor
9181010-36	9181010-35		9181010-35		Compressor Relay
Internal	Internal		Internal		Overload
CIM0836W		CIM1136W		CIM1137W	Starting Components (Included in Comp Kit)
9181177-11		9181180-11		9181181-11	Compressor Kit
9181003-44		9181003-44		N/A	Start Capacitor
9181009-16		9181009-16		N/A	Run Capacitor
9181010-37		9181010-33		N/A	Compressor Relay
Internal		Internal		Internal	Overload
CIM0835W		CIM1135W			Starting Components (Included in Comp Kit)
9181176-11		9181182-11			Compressor Kit
9181003-53		9181003-56			Start Capacitor
9181009-16		9181009-27			Run Capacitor
9181010-36		9181010-35			Compressor Relay
Internal		Internal			Overload
CIM0836R	CIM0835R	CIM1136R	CIM1135R	CIM1137R	Starting Components (Included in Comp Kit)
9181177-11	9181176-11	9181180-11	9181182-11	9181181-11	Compressor Kit
9181003-44	9181003-53	9181003-44	9181003-56	N/A	Start Capacitor
9181009-16	9181009-16	9181009-16	9181009-27	N/A	Run Capacitor
9181010-37	9181010-36	9181010-33	9181010-35	N/A	Potential Relay
Internal	Internal	Internal	Internal	Internal	Overload

Reference the Bristol Model Number for Compressor Starting Components	1051239-01 Copeland Kit	9181176-11	Bristol R92J243ABKA
	1051240-01 Copeland Kit	9181177-11	Bristol R92J223ABCA
	1051240-02 Copeland Kit	9181180-11	Bristol R92J273ABCA
	1051240-03 Copeland Kit	9181181-11	Bristol R92J273DBLA
	1051241-02 Copeland Kit	9181182-11	Bristol R92J343ABKA

Reference the Copeland Model Number for Compressor Starting Components	1051239-01	Copeland	9181139-11	CS10K6E-PFV-255
	1051240-01	Copeland	9181240-11	CS12KIE-PFV-255
	1051240-02	Copeland	9181140-12	CS12K6E-PFJ-255
	1051240-03	Copeland	9181140-13	CS12K6E-TF5-255
	1051241-02	Copeland	9181141-12	CS14K6E-PFJ-255

9181139-11	9181240-11	9181140-12	9181140-13	9181141-12	Compressor Kit
9181003-07	9181003-44	9181003-32	N/A	9181003-07	Start Capacitor
9181009-16	9181009-12	9181009-17	N/A	9181009-12	Run Capacitor
9181010-12	9181010-10	9181010-04	N/A	9181010-12	Potential Relay
Internal	Internal	Internal	Internal	Internal	Overload

Wiring harness service kits are now available to provide a specific connector to be replaced due to a damaged connector or wire.

<u>Kit Part Number</u>	<u>Components Serviced</u>	<u>Voltage</u>
1051237-01	Water Pump, Harvest Assist, Hot Gas Valv 115 or 230	115 or 230
1051237-02	Low Float Switch, High Float Switch, Thermistor, Curtain Switch	12 Volt D.C.

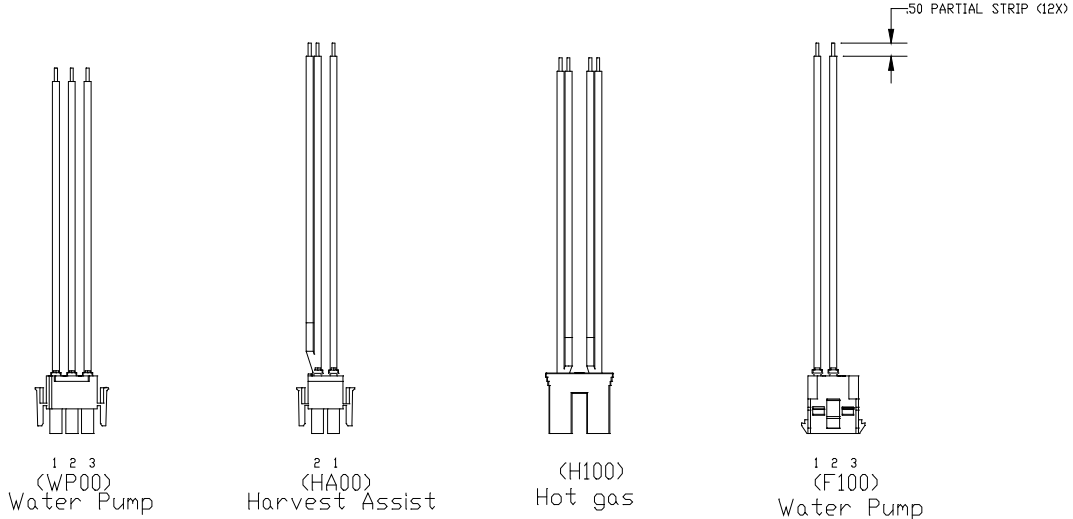

KIT, WIRING HARNESS, LINE VOLTAGE
1051237-01

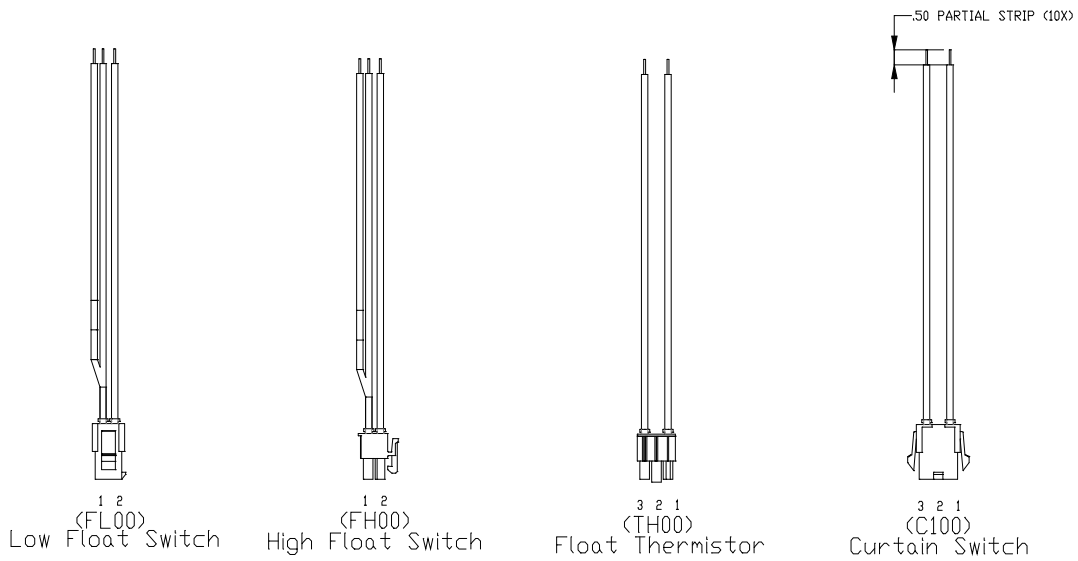

KIT, WIRING HARNESS, SIGNAL VOLTAGE
1051237-02